

**OPERATING INSTRUCTIONS FOR PETERSEN® 151-SERIES HIGH LIFT FLANGE
TEST & WELDING PLUGS**

SIZES 3/4" TO 8"

These operating instructions give step-by-step instructions on the use of the high lift flange test & welding plug. This plug can be used in two different configurations as a test plug and a welding plug. The test plug configuration allows the flange to pipe weld to be tested after welding. The weld plug configuration aids in the welding of the flange to pipe while monitoring upstream pressure and also allows the weld to be tested after welding. Follow steps labeled **TP** for test plug configuration, **WP** for weld plug configuration and **TP WP** for both.

WARNING!

- **PRESSURE TESTING IS INHERENTLY**
- **DANGEROUS. STRICT ADHERENCE TO THESE OPERATING INSTRUCTIONS AND INDUSTRY SAFETY PRACTICES COULD PREVENT INJURY TO PERSONNEL**
- **ALL PERSONNEL MUST BE CLEAR OF TEST PLUG WHEN PRESSURE TESTING. FOR SAFETY, AN INCOMPRESSIBLE LIQUID, SUCH AS WATER, SHOULD BE USED AS THE TEST MEDIUM. RESIDUAL AIR OR GAS IS TO BE EVACUATED FROM THE PIPE PRIOR TO TESTING.**

PRIOR TO USE

- Verify stamping on washer is equivalent to the pipe size being tested. The washer should be stamped with the flange size and pipe schedule.
Example: The stamp "1P80" should be interpreted as 1" Sch 80 pipe sizes. The seal OD should be the same as the washer OD.
- Inspect the raised face (gasket surface) of the Flange Plug and mating flange to be tested. Damage or surface imperfections may result in leakage and should be repaired prior to testing.
- Clean and dry the pipe ID. Remove all moisture, debris and excessive scale.

Step 1

TP ATTACHMENT OF TEST PLUG TO MATING FLANGE

- Any weld droop or spatter that protrudes into pipe ID more than clearance listed in Table 1 must be removed to allow plug installation.
- If installation depth is limited in length of pipe one of the compression tubes between the flange and seal can be moved to the opposite side of the flange to reduce the distance between seal and flange. For 3/4" – 1" sizes the compression tube that is being repositioned must be placed between the Flange/Fill-Vent Port tube assembly and the Upstream monitor Port Tube. (See Table 1)
- Apply gasket to mating flange face and position Flange Plug against mating flange. Rotate plug as required locating purge vent at highest point and installing flange bolts. Tighten bolts in a cross-like pattern to properly seal the flange gasket.

WP ATTACHMENT OF WELDING PLUG SET-UP TO MATING FLANGE

- The distance between the flange and the washer and seal assembly should be approximately 12". If not, check to see both compression tubes are installed between the flange and seal and washer assembly.
- Locate the flange to be welded on the pipe using an alignment tool (*The Flange Test & Welding Plug is not designed to support or position flange to be welded*). Apply gasket to mating flange face and insert the Flange plug into the flange and pipe with the inert gas purge ports oriented at the top and bottom of the flange. Tighten bolts in a cross-like pattern to properly seal the flange gasket.

STEP 2

TP WP TIGHTENING AND EXPANSION OF SEAL ELEMENT

- Correct tightness of hex nut is critical to the operation of the Flange Test & Welding Plug. A leak of the seal is usually an indication the hex nut(s) was not adequately tightened. The normal torque listed in Table 1 should be adequate for most installations, however due to variations within pipe ID finishes the torque may need to be increased up to the maximum torque value listed in Table 1. If at the maximum torque the plug still leaks, verify the correct seal and washers are being used.

For Sizes ¾" to 2 ½"

- Tighten hex nut to normal installation torque listed in Table 1 using a calibrated torque wrench. If shaft spins while hex nut is being tightened, a crowsfoot and a pipe wrench/opened end wrench must be used. (*See Table 1 for crowsfoot sizes*)

For Sizes 3" – 8"

- For sizes 3" and larger, tighten the hex nut by hand to remove any slack from the parts. Then use a ¾" drive or larger impact wrench capable of producing the torque values listed in Table 1. A deep impact socket is required (*See Table 1 for impact socket sizes*.) The use of an impact wrench will prevent the shaft from spinning and enable the counting of turns listed in Table 1 to reach the required torque.
- If an impact wrench and deep socket are not available, two pipe wrenches may be used. The second is required to hold the shaft while turning the hex nut the required number of times.
- The torque may be checked with a calibrated torque wrench and should be between the normal and maximum values listed in Table 1.
 - **NOTE: The torque required to seal plug sizes 3" to 8" is greater than the torque used to bolt up to 300lb flange when using a spiral wound metal gasket.**

STEP 3

WP PREPARATION FOR WELDING

Make connection for upstream monitor port that will clearly indicate an increase of pressure or the presence of dangerous gases. In addition upstream vapors may be vented by attaching approximately 50ft. of hose to the vent port and locating the end of the hose downwind from the weld area.

For normal conditions where Inert Gas Purge is not required:

- Remove pipe plugs from fill and vent plugs on the flange or make connections to fill and vent ports as required by welding safety procedures.

If Inert Gas purge is required:

- Remove pipe plugs from the fill and vent ports on the flange
- Connect Inert Gas supply to fill port. Make connections to vent port as required to monitor or regulate the flow of Inert Gas.
- Initiate Inert Gas Purge and adjust Inert Gas pressure regulator as required to maintain a slight positive pressure during welding. As welding proceeds, adjust Inert Gas flow as needed to insure weld quality.

STEP 4

WP WELDING

- **Note: Do not let the weld protrude into the pipe ID by more than the values listed in Table 1 or grinding of the pipe ID may be required for plug removal.**
- Begin welding the flange to the pipe while monitoring upstream pressure. Stop welding immediately if the upstream pressure increases which indicates flow in the line. During welding the pipe at the seal location must not become too hot to touch by hand. Should the pipe in the seal location become too hot to touch by hand, discontinue welding and allow pipe to cool.

STEP 5

TP WP HYDROSTATIC PRESSURE TEST

- ***WARNING: NEVER ATTEMPT TO ADJUST THE FLANGE TEST & WELDING PLUG WHILE UNDER PRESSURE. NEVER EXCEED THE TEST PRESSURES IN TABLE 2.***
- Remove the vent plug. Connect hydro pump to fill port on Flange. Slowly begin to fill the plug until water flows from the vent. Discontinue water input and install the vent plug leak tight. Refer to Table 2 for the maximum test pressure for the Flange Test Plug. The test pressure must never exceed the strength of the weakest component in the system being tested. Slowly introduce the test pressure. If a pressure decay test will be conducted, hold at desired pressure with pump for a minimum of 5 minutes prior to closing isolation valve. This will allow parts to settle. Continue holding the desired pressure to meet testing requirements. If pressure drops off a large amount or a leak between seal and tube ID is detected, tighten the hex nut until leak is sealed. (*Do not exceed maximum installation torque*). After the test is completed, release all pressure. Remove the fill and vent plugs to drain water. Remove all testing equipment. Loosen the hex nut(s) to fully relax seal. Loosen and remove hex nuts and flange mounting bolts. Withdraw the Flange Test Plug from the pipe.

INSPECT PLUG AFTER EACH USE

- Surface imperfections on the flange face should be fixed prior to further testing.
- Replace worn or damaged seals.
- Clean and dry plug prior to storage.
- Store these instructions with plug.

TABLE 1 High Lift Flange Weld Test Plug Clearance and Suggested Installation Torque Values

Nom. Plug Size	Clearance Between Plug & Pipe (in)	Normal Installation Torque	Maximum Installation Torque	Wrench Size to Hold Shaft (in)	Crowsfoot Size (in)
3/4"	0.07	50 in-lbs	Do Not Exceed Normal Torque	9/16"	9/16"
1"	0.11	100 in-lbs	200 in-lbs	9/16"	9/16"
1-1/4"	0.13	25 ft-lbs	40 ft-lbs	1/2"	15/16"
1-1/2"	0.17	25 ft-lbs	40 ft-lbs	1/2"	15/16"
2"	0.26	35 ft-lbs	50 ft-lbs	1/2"	15/16"
2-1/2"	0.25	100 ft-lbs	200 ft-lbs	7/8"	2"

Nom. Plug Size	Clearance Between Plug & Pipe (in)	Normal Installation Torque	Maximum Installation Torque	Estimated Number of Turns of Hex Nut	Wrench Size to Hold Shaft (in)	Deep Impact Socket Size (in)
3"	0.38	200 ft-lbs	400 ft-lbs	5	7/8"	2"
4"	0.44	200 ft-lbs	400 ft-lbs	5	7/8"	2"
6"	0.50	400 ft-lbs	900 ft-lbs	6	1-5/8"	3-1/8"
8"	0.50	400 ft-lbs	900 ft-lbs	6	1-5/8"	3-1/8"

*Under normal conditions a 200lb man would require at least a 1ft lever to achieve 200 ft-lbs. The same man would require at least a 2ft lever to achieve 400 ft-lbs.

TABLE 2 Flange Weld Test Plug Working Pressures

Class	Maximum Test Pressure (PSI)
150 lbs	450
300 lbs	1125
600 lbs	1125

REPLACEMENT SEAL & WASHER PROCEDURE

3/4" – 1" Plug Sizes (refer to Figure 1)

1. Remove hex nut & jam nut from bottom of shaft.
2. Remove bottom washer, seal and washer from shaft.
3. Install first washer, seal and second washer.
4. Install jam nut onto shaft as far as possible. Install hex nut and wrench tighten hex nut against jam nut.

5. Plug is ready for testing.

1 ¼” – 3” Plug Sizes (refer to Figure 2)

1. Remove hex nut & jam nut from shaft.
2. Remove washer, seal and O-ring washer from shaft taking care not to damage O-ring in ID of washer. Inspect O-ring and replace if worn or damaged.
3. Lubricate O-ring in ID of washer with grease and carefully install washer onto shaft.
4. Install seal and washer.
5. Install jam nut onto shaft as far as possible. Install hex nut and wrench tighten hex nut against jam nut.
6. Plug is ready for testing.

4” – 8” Plug Sizes (refer to Figure 3)

1. Remove hex nut & jam nut from shaft.
2. Remove washer, seal and O-ring washer from shaft taking care not to damage O-ring in ID of washer. Inspect O-ring and replace if worn or damaged.
3. Lubricate O-ring in ID of washer with grease and carefully install washer onto shaft so that tapered side will be positioned against seal.
4. Install seal and tapered washer, so that tapered side will be positioned against seal.
5. Install jam nut onto shaft threads first as far as possible. Install hex nut and wrench tighten hex nut against jam nut.
6. Plug is ready for testing.

Figure 1. High Lift Flange Weld Test Plug ¾” and 1” Plug Sizes. Shown in WP Configuration

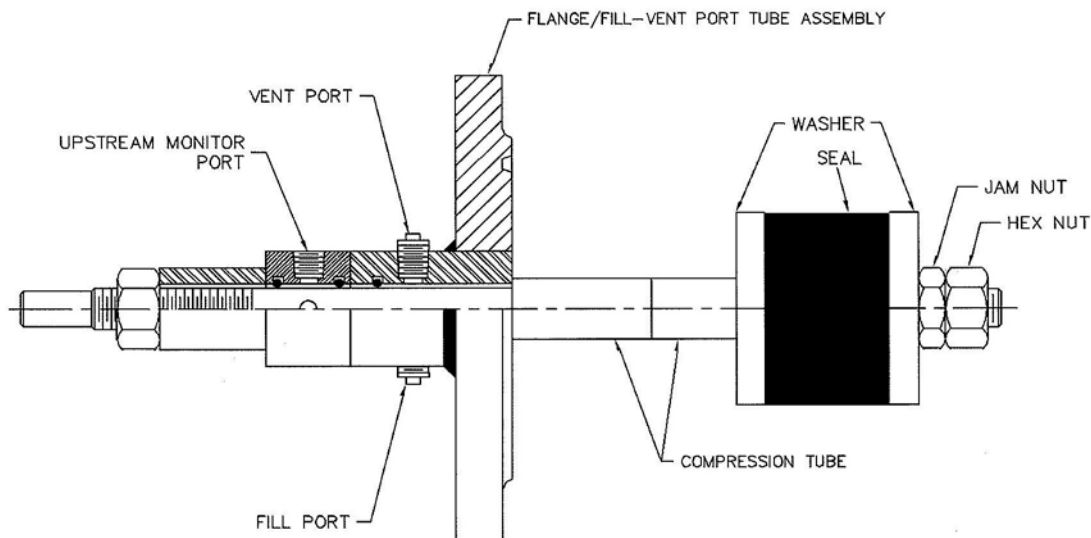

Figure 2. High Lift Flange Weld Test Plug. 1 1/4" through 3" Plug Sizes. Shown in WP Configuration

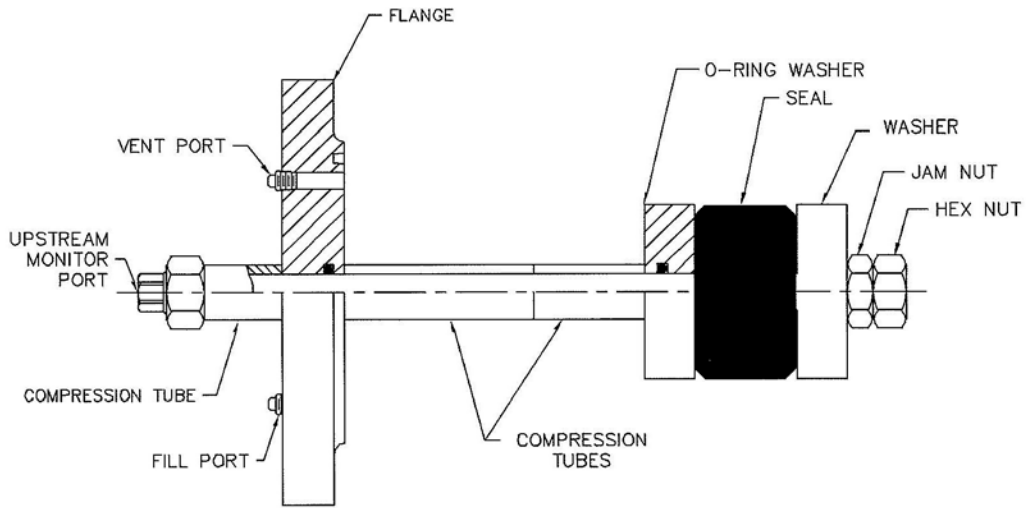
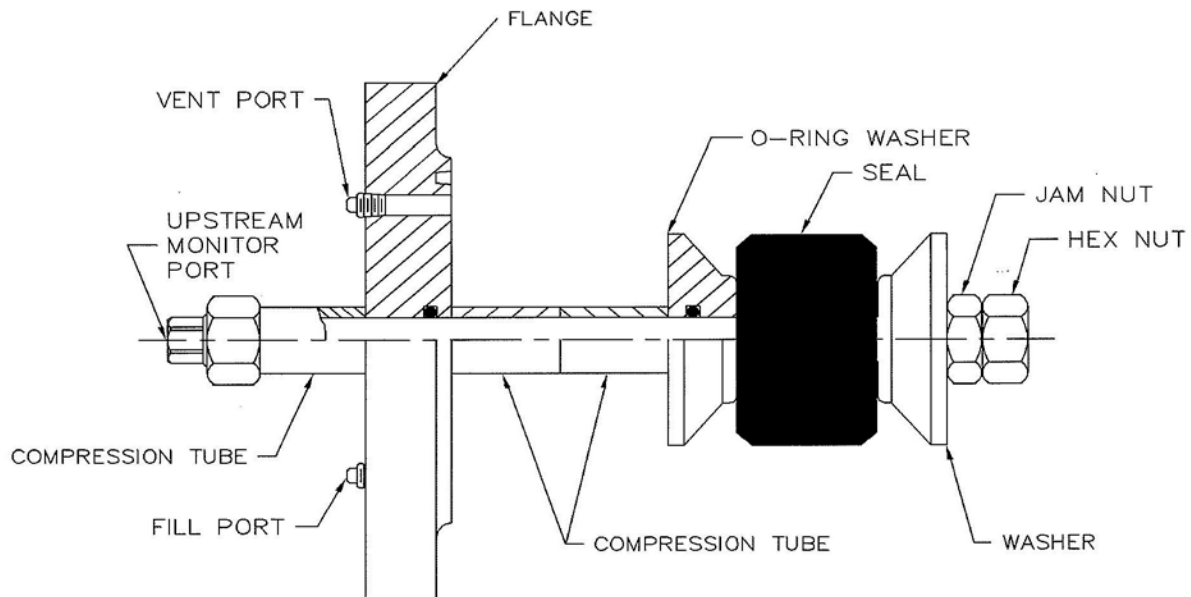

Figure 3. High Lift Flange Weld Test Plug. 4" through 8" Plug Sizes. Shown in WP Configuration



PP 151 Series Operating Instructions High Lift Flange To 8in.doc Rev 02/10

PO Box 340
421 Wheeler Ave.
Fredonia, WI 53021-0340 USA

Tel: 800-926-1926, 262-692-2416
Fax: 800-669-1434, 262-692-2418
E-Mail mail@petersen.cc

WE LOVE TO SERVE our Customers

QUALITY PRODUCTS SINCE 1916